

New Software
Version 2.5

FLUKE®

HART® Transmitter Calibration

Application Note



Why use "smart" instrumentation?

Like most process plants, your organization is probably facing the dual challenges of maximizing productivity while minimizing maintenance costs. "Smart" digital transmitters offer superior performance and reliability, while saving time and effort in maintenance and calibration. Manufacturers of field instruments have helped accelerate the changeover by offering smart transmitters at prices nearly as low as analog units. As digital instruments using the HART protocol quickly become the standard, communicators and calibrators are becoming essential everyday tools.

What is HART?

HART, the Highway Addressable Remote Transducer protocol, uses a 1200 baud Frequency Shift Keying (FSK) signal to superimpose digital information on the conventional 4–20 mA analog signal.

Why use the HART protocol?

HART is an industry standard developed to define the communications protocol between intelligent field devices and a control system, HART is the most widely used digital communication protocol in the process industry. More than five million HART field instruments are installed in more than 100,000 plants worldwide. The HART protocol:

- Is supported by all of the major suppliers of process field instruments supported by the HART Communication Foundation,



an industry-wide non-profit organization. See the Web site [HYPERLINK http://www.hartcomm.org](http://www.hartcomm.org) for information on the HART standard.

- Preserves present control strategies.
- Allows traditional 4-20 mA signals and digital communication to share the same two-wire loops.
- Provides important information for installation and maintenance: Tag IDs, measured values, range and span data, product information and diagnostics.
- Reduces operation costs by making it easier to manage and fully utilize "smart" instrument networks.

HART calibration is required!

A common misconception is that the accuracy and stability of HART instruments eliminate the need for calibration.

Another misconception is that calibration can be accomplished by re-ranging field instruments using only a HART communicator. Still another misconception is that the control system can remotely calibrate smart instruments. *These are not true.* All instruments drift. Re-ranging with just a communicator is not calibration. A precision calibrator or standard is required. Regular performance verification with a calibrator traceable to national standards is necessary due to:

1. Shifts in performance of electronic instruments over time, due to exposure of the electronics and the primary sensing element to temperature, humidity, pollutants, vibration, and other field environmental factors.

2. Regulations governing occupational safety, consumer safety, and environmental protection.
3. Quality programs such as ISO 9000 standards for all instruments that impact product quality.
4. Commercial requirements such as weights, measures, and custody transfer.

Regular calibration is also prudent since performance checks will often uncover problems not directly caused by the instrumentation, such as solidified or congealed pressure lines, installation of an incorrect thermocouple type, or other errors and faults.

A calibration procedure consists of a verification (As Found) test, adjustment to within acceptable tolerance if necessary, and a final verification (As Left) test if an adjustment has been made. Data from the calibration are collected and used to complete a report of calibration, documenting instrument performance over time.

All instruments, even HART instruments, must be calibrated on a regular, preventive maintenance schedule. The calibration interval should be set short enough to insure that an instrument never drifts out of tolerance, yet long enough to avoid unnecessary calibrations. Alternatively, the interval may be determined by critical process requirements, e.g., calibration before each batch.

How are HART instruments properly calibrated?

To calibrate a HART instrument consistent with its application, it is very helpful to understand the functional structure of a typical HART transmitter. The article in Appendix A, by Kenneth L. Holladay of Southwest Research Institute, describes a typical HART instrument and defines both proper and improper calibration practices. Originally published in *Intech*, May 1996, it is reprinted with permission of the author.

Note: If you are unfamiliar with HART calibration or need a review, this is an excellent point to stop and read the article in Appendix A. It covers the basics of HART instrumentation and addresses issues critical to instrument maintenance.

HART instruments consist of three distinct sections (see Figure 1). Proper HART calibration may involve either or both sensor trim and output trim. Adjusting range values (LRV and URV) without a calibrator is not calibration. Performing an output trim while ignoring the input section is not proper calibration. *Adjusting range values with a calibrator may be a practical calibration alternative for instruments operated in 4-20 mA analog mode, provided that the PV and PVAO are not used for process control.*

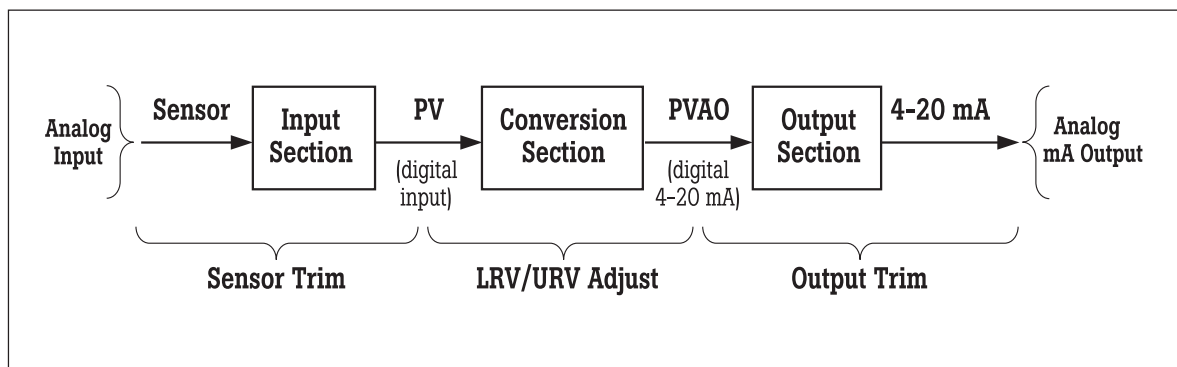
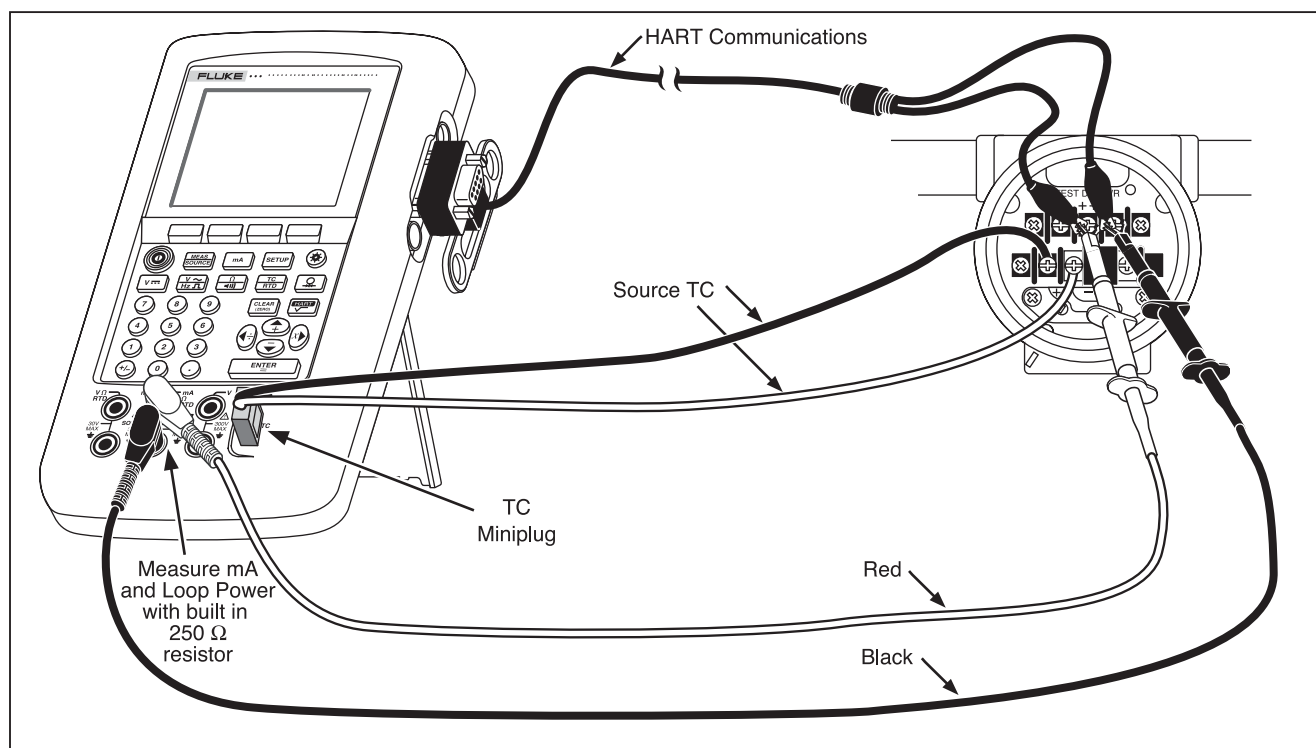

Figure 1

It's easy to calibrate and maintain HART instrumentation with one powerful tool.



With the 744 DPC, you can:

- Generate precision electrical, temperature, or pressure signals for analog stimulus or sensor simulation.
- Simultaneously measure electrical, temperature, or pressure signals from transmitter output.
- Determine type, manufacturer, model, tag ID by interrogating HART devices.
- Read HART PV function and smart transmitter digital output while measuring analog mA output.
- Read and write HART configuration functions to make field adjustments to PV range points, damping, and other top-level configuration settings.
- Change sensor configuration on supported temperature transmitters.
- Re-label smart transmitters by reading and writing HART tag and message fields.
- Clone additional transmitters by reading and storing basic HART configurations.
- Perform automated HART sensor trim and output trim for selected devices in conjunction with As Found/As Left tests.
- Perform loop test with simultaneous analog and digital mA readout.
- Address new, fast, pulsed-excitation smart transmitters and PLCs.

- Control Hart Scientific Dry Block Calibrator.
- No need for separate HART communicator.

744 upgrades available

Fluke periodically releases new internal software for the Fluke 744. These upgrades include:

- New revisions of previously supported instruments.
- Device-specific command support for new instruments.
- New HART communication capability.

The upgrade can be easily loaded from a PC to a 744.

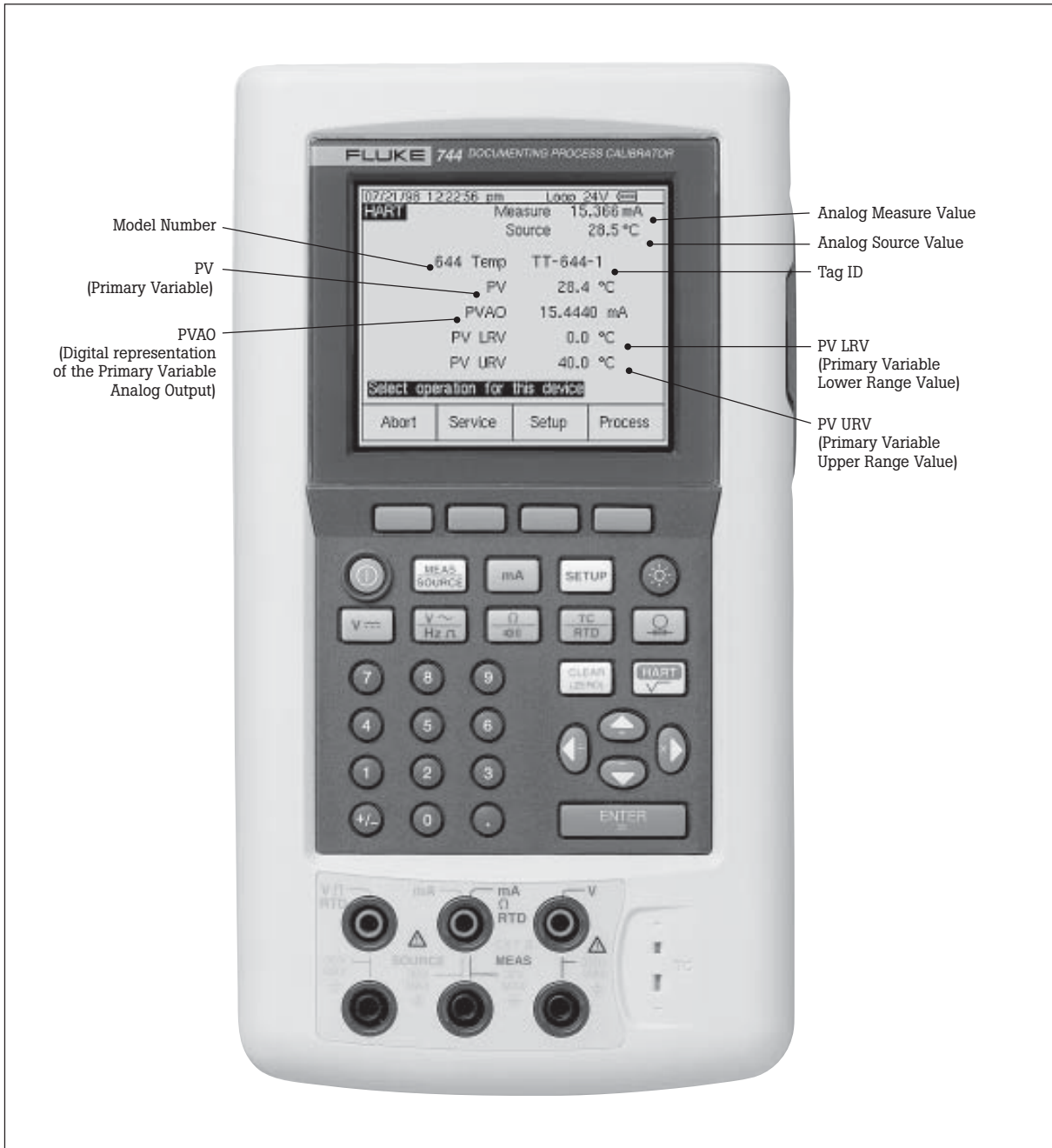

Model Number

PV
(Primary Variable)

PVAO
(Digital representation
of the Primary Variable
Analog Output)

Analog Measure Value

Analog Source Value

Tag ID

PV LRV
(Primary Variable
Lower Range Value)

PV URV
(Primary Variable
Upper Range Value)

Hart Applications

Versatile HART protocol support

The Fluke 744 supports the commands contained in HART protocol version 5.7. With 2 MB of memory, the 744 supports a substantial set of HART instructions:

- **Universal commands** – provide functions that are implemented in all field devices, for example, read manufacturer and device type, read primary variable (PV), or read current output and percent of span
- **Common practice commands** – provide functions that are common to many but not all field devices, for example read multiple variables, set damping time, or perform loop test
- **Device-specific commands**— provide functions that are unique to a particular field device, for example sensor trim. The 744 Version 2.0 supports these devices:

HART operating modes supported

- For **Point to Point operation**, the most commonly used mode, connects the 744 to a single HART device in a 4–20 mA loop.
- In **Multi-Drop** mode, several HART instruments can be bussed together. The 744 searches for each, identifies addresses in use, and allows you to select the instrument for calibration and related operations.
- In **Burst Mode**, the HART instrument transmits bursts of data without waiting to be interrogated by a master unit. The 744 can take transmitters out of burst mode during test or calibration, then later restore them to burst mode.

Is there still a role for the communicator?

Commissioning a HART instrument or modifying HART variables not supported by the 744 requires the use of a communicator. The 744 is designed to perform the vast majority of day-to-day operations you normally perform with a separate communicator. The HART capability of the 744 is comparable to that of the model 275 HART communicator, with the exception of the DD interpreter. While the DD interpreter enables the 275 communicator to read command set libraries from any HART supplier, it offers capabilities far beyond those generally required for daily HART instrument maintenance.

HART calibration applications

The following examples demonstrate how the 744 makes HART calibration an efficient operation. The 744 enables easy hookup using its HART cable, fast access to the most important HART data, automatic branching to appropriate adjustment choices, automatic completion of test templates, and automatic *fetching* and *sending* of analog readings during trim.

Manufacturer	Pressure Instruments	Temperature Instruments	Coriolis Instruments
ABB/Kent-Taylor	600T	658T ¹	
ABB/Hartmann & Braun	Contrans P, ¹ AS 800 Series		
Endress & Hauser	CERABAR S, CERABAR M, DELTABAR S	TMT 122 ¹ , TMT 182 ¹ , TMT 162 ¹	
Foxboro Eckardt		TI/RTT20 ¹	
Foxboro/Invensys	I/A Pressure		
Fuji	FCX FCXAZ	FRC	
Honeywell	ST3000	STT25T ¹ , STT25H ¹	
Micro Motion			2000 2000 IS 9701 9712 9739
Moore Products		344 ¹	
Rosemount	1151 2088 3001C 3051, 3051S	3044C 644 3144 3244, 3144P	
Siemens	SITRANS P DS SITRANS P ES	¹ Sensor Trim not supported	
SMAR	LD301	TT301 ¹	
Viatran	I/A Pressure		
Wika	UNITRANS	T32H ¹	
Yokogawa	EJA	YTA 110, 310 and 320	

Table 1

¹Sensor Trim not supported

What's new in Version 2.5

- **Device-specific calibration support for new instruments:**
 - Micro Motion 2000, 2000 IS, 9701, 9712 and 9739 coriolis flow transmitters
 - Fuji FCX and FCXAZ pressure and FRC temperature transmitter
- **New features:**
 - Support for New Hart Scientific dry blocks: 7103, 9007, 9011, 9023, 9103, 9105, 9107, 9122, 9127, 9132, 9133 and 9150
 - Enhanced dry block delay setting for temperature switch testing
 - Switch test without reset

Example 1

Calibration of a Rosemount 3051 HART Pressure Transmitter

Basic connections

This example assumes that the transmitter is isolated from the process and is not electrically connected to a loop power supply. Make basic connections to the 3051 per the diagram in Figure 4. Polarity of the HART communication connection is not important. A separate 250 ohm resistor is not necessary because the 744 incorporates a resistor in series with the 24V loop supply through its mA jacks. The 3051 in this example is configured for psi units.

Procedure

1. Power on the Fluke 744 Calibrator. Press the red **MEAS** key followed by the **Loop Power** softkey and the 744 will display the basic HART information for the 3051 (Figure 5).

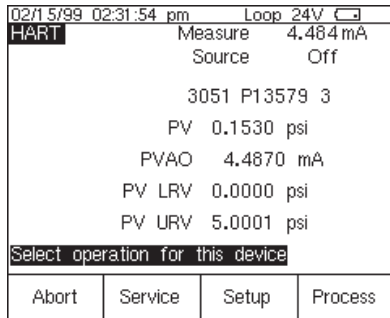

Figure 5

2. Press the **ENTER** key again and you are prompted to select the 744 configuration (Figure 6). Selecting **MEAS mA, SOURCE psi** will configure the calibrator to measure the analog mA output and the pressure being applied simultaneously to the transmitter input and the pressure module. (Selecting **MEAS PV, SOURCE psi** will configure the 744 to evaluate the digital PV output from the transmitter.) Press **ENTER** to select.

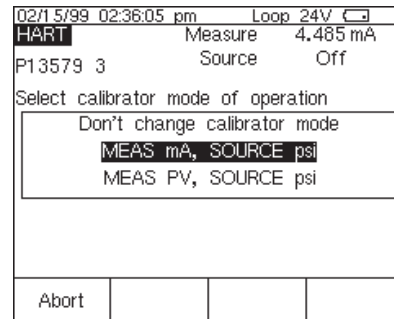

Figure 6

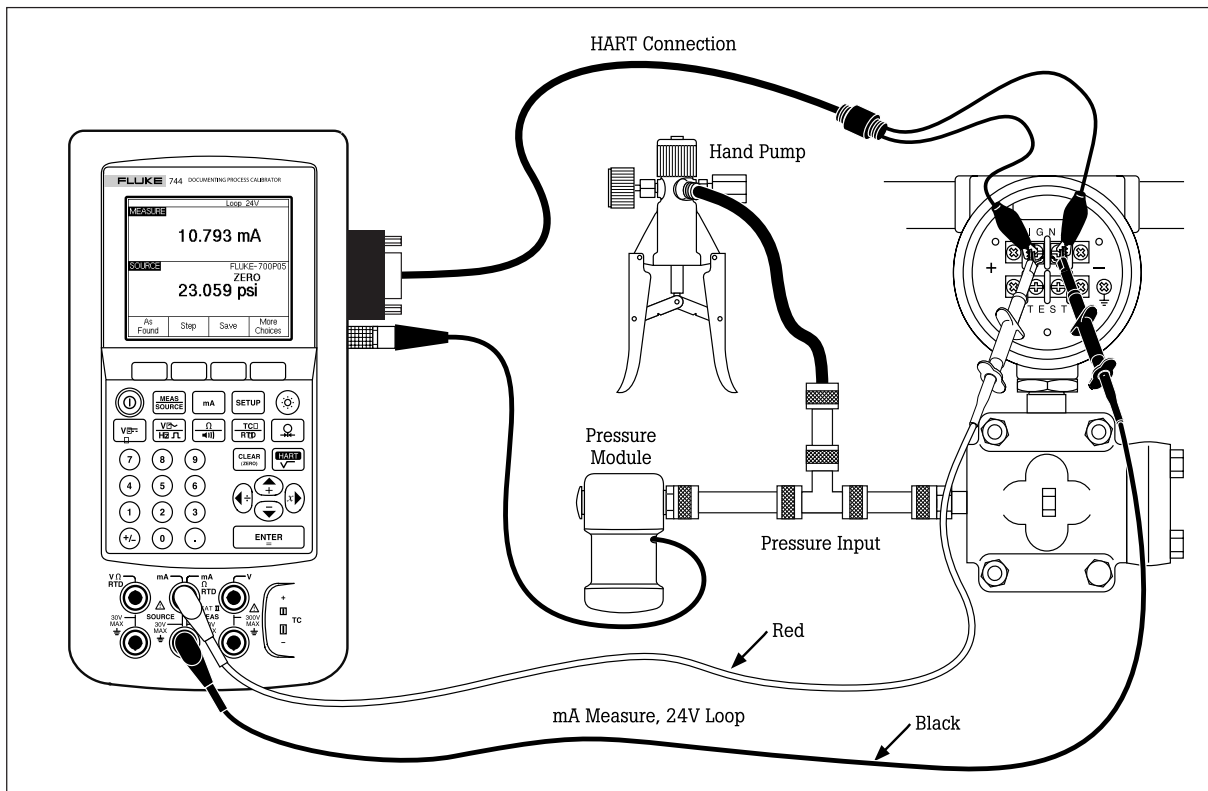

Figure 4

3. Vent the pressure line and press **CLEAR** to zero the pressure module. Press the **As Found** softkey, and then press **ENTER** to select **Instrument** for a linear transmitter calibration. (If the 3051 is configured for square root output, select **✓ Instrument**.) Notice that the calibration template is automatically completed with the exception of Tolerance. Fill in the appropriate test tolerance and press **Done**.
4. Press the **Manual Test** softkey to begin calibration. Apply the input pressures as instructed in the SOURCE screen. Press the **Accept Point** softkey when the correct pressure is applied for each point. When the test is complete, the error summary table is displayed (Figure 7). Test errors exceeding the tolerance are highlighted. When done viewing the table, press the **Done** softkey. Press **Done** again to accept, or **ENTER** to change the tag, serial number or ID fields.

SOURCE	MEASURE	ERROR %
0.000 psi	4.487 mA	3.04
2.502 psi	12.382 mA	2.35
5.000 psi	20.268 mA	1.68

Abort	Prev. Page	Next Page	Done
-------	------------	-----------	------

Figure 7

5. If the As Found test failed (i.e., there were highlighted errors in the error summary table), adjustment is necessary. Press the **Adjust** softkey. Select **Sensor Trim** and press **ENTER**. (Do not select **Pressure Zero Trim**. It is the same as trimming the lower sensor point at zero, which is useful for pressure transmitters that do not offer Sensor Trim.) The 744 screen should look like Figure 8.

02/15/99 03:24:14 pm Loop 24V			
HART SERVICE	Measure	4.016 mA	
P13579 3	Source	0.014 psi	
Select sensor trim operation			
Perform user trim - both			
Perform user trim - lower			
Perform user trim - upper			
Select factory data			
Abort			

Figure 8

6. Select **Perform user trim - both** and press **ENTER**. Zero the pressure module (vented to atmosphere) by pressing **CLEAR**. Press the **Continue** softkey and you are prompted for the Lower Trim value. For best results, apply the LRV pressure and press **Fetch** to load the value being measured by the pressure module. Press **Trim**. Then press **Continue** to move to the Upper Trim. As before, apply the URV pressure, press **Fetch**, and press **Trim**. If the 3051 is used with the digital PV output, skip to step 8 and perform the As Left test. If the 4-20 mA analog output is used in the process, continue on to step 7.

7. Select **Output Trim** and press **ENTER**. The value of the primary variable (PVAO) is in the upper right corner of the display. This is normally a 4 mA signal. The mA value, as constantly measured by the Fluke 744, is in the center of the display. Press the **Fetch** softkey to load the measured mA value. Press **Send** to send the value to the 3051 to trim the output section for the 4 mA value. Press **Continue** for the 20 mA trim and repeat this step.
8. After completing Output Trim, press the **Done** softkey and proceed with the As Left verification test. Press the **As Left** softkey. Press **Done** and then press **Manual Test**. Apply the requested pressures and press **Accept Point** when the readings are stable. On completion an error summary table is displayed. If none of the errors are highlighted (Figure 9), the 3051 passes the calibration test. If errors are highlighted, the test has failed and further adjustment is required. Return to step 5 for adjustment of the 3051.

SOURCE	MEASURE	ERROR %
0.001 psi	3.999 mA	-0.03
2.500 psi	11.997 mA	-0.02
5.000 psi	19.998 mA	-0.01

Abort	Prev. Page	Next Page	Done
-------	------------	-----------	------

Figure 9

Example 2

Calibration of a Rosemount 3144 HART Temperature Transmitter

Basic connections

This example assumes that the transmitter is isolated from the process and is not electrically connected to a loop power supply. Make basic connections to the 3144 per the diagram in Figure 10. Polarity of the HART communication connection is not important. A separate 250 ohm resistor is not necessary because the 744 incorporates a resistor in series with the 24V loop supply through its mA jacks. The 3144 in this example is configured for a type K thermocouple sensor with a span of 0-300 °C.

Procedure

1. Power on the Fluke 744 Calibrator. Press the red **MEAS** key followed by the **Loop Power** softkey. Press **ENTER** to bypass the warning screens and the 744 will display the basic HART information for the 3144 (Figure 11).

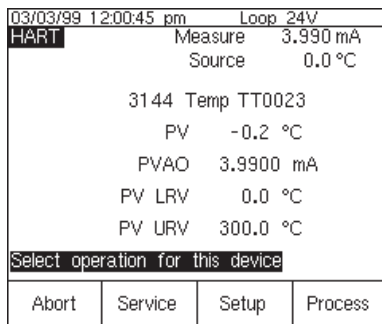

Figure 11

2. Press the **MEAS** key again and you are prompted to select the 744 configuration (Figure 12). Selecting **MEAS mA, SOURCE T/C typ K** configures the calibrator to measure the analog mA output of the transmitter and source the correct temperature stimulus at the 3144 input. (Selecting **MEAS PV, SOURCE T/C typ K** will configure the 744 to evaluate the digital PV output from the transmitter.) Press **ENTER** to select.

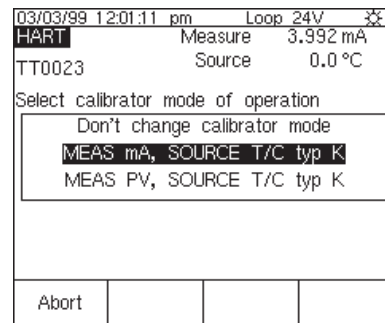

Figure 12

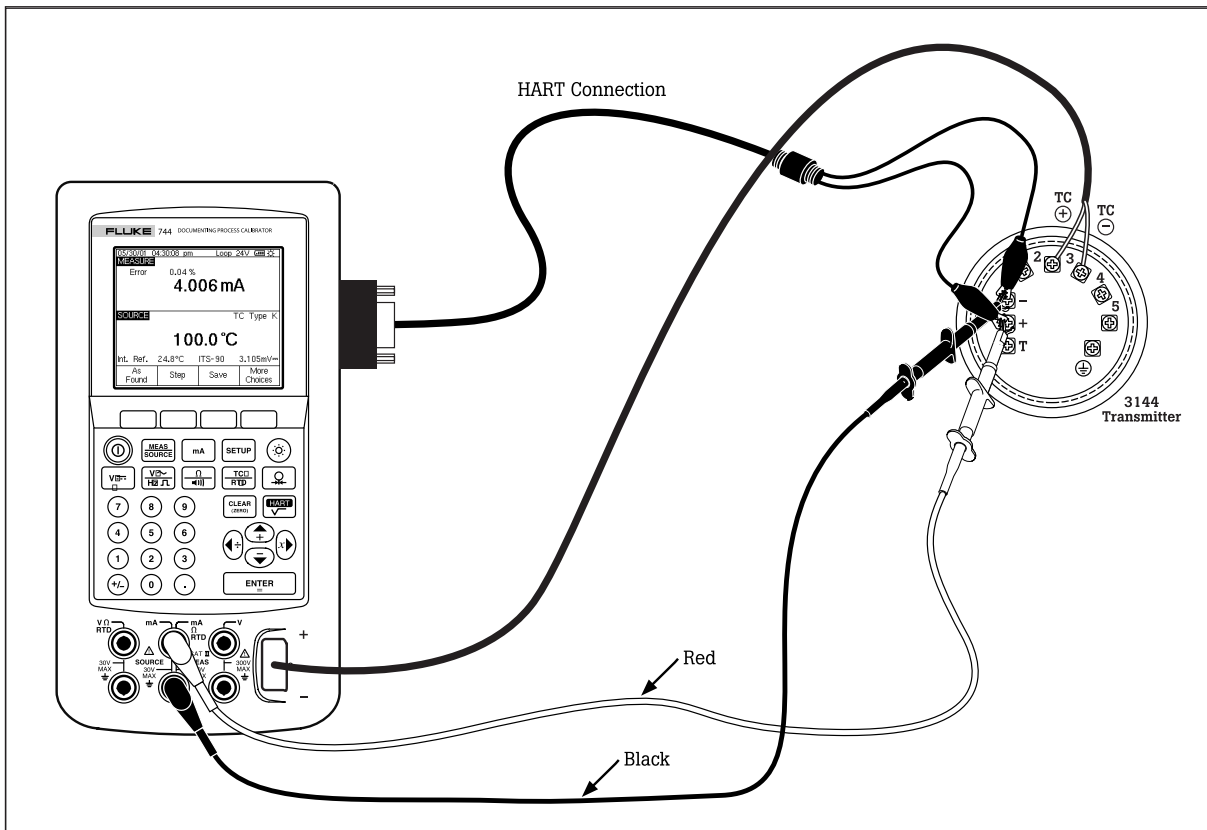

Figure 10

- Press the **As Found** softkey, and then press **ENTER** to select **Instrument** for a linear transmitter calibration. Notice that the calibration template is automatically completed with the exception of the Tolerance. Fill in the appropriate test tolerance and press the **Done** softkey.
- Press the **Auto Test** softkey to begin calibration. Once the test is complete, an error summary table is displayed (Figure 13). Test errors exceeding the tolerance are highlighted. When done viewing the table, press the **Done** softkey. Press **Done** again to accept, or **ENTER** to change the tag, serial number or ID fields.
- If the As Found test failed (i.e., there were highlighted errors in the error summary table), adjustment is necessary. Press the **Adjust** softkey. Select **Sensor Trim** and press **ENTER**. Select **Perform user trim – both** and press **ENTER**. The 744 screen should look like Figure 14.

SOURCE	MEASURE	ERROR %
0.0 °C	3.948 mA	-0.33
150.0 °C	11.972 mA	-0.17
300.0 °C	20.000 mA	0.00

02/17/99 04:27:38 pm Loop 24V **ENTER**

Abort Prev. Page Next Page Done

Figure 13

- For best results, press **LRV** to apply the LRV for the Lower Trim value. Press **Trim** and then **Continue** to move to the Upper Trim. Press **URV**, press **Trim**, and then press **Done**. If the 3144 is used with the digital PV output, skip to step 8 and perform the As Left test. If the analog 4–20 mA output is used in the process, continue on to step 7.

Last Trim	Value
Last Trim	-25.8 °C
744 Source	0.0 °C
ENTER value in the range:	
	-180.0 to 1372.0 °C
Lower Trim:	0 °C

02/17/99 04:45:23 pm Loop 24V **ENTER**

HART SERVICE PV 0.0 °C

Abort LRV Trim

Figure 14

- Select **Output Trim** and press **ENTER**. The value of the primary variable (PVAO) is in the upper right corner of the display. (Figure 15). This is normally a 4 mA signal. The mA value, as constantly measured by the Fluke 744, is in the center of the display. Press the **Fetch** softkey to load the measured mA value. Press **Send** to send the value to the 3144 to trim the output section for the 4 mA value. Press **Continue** for the 20 mA trim and repeat this step.

744 Measure	Value
744 Measure	3.961 mA
Fetch or ENTER value	
Trim Current:	0.0000 mA

02/17/99 04:49:14 pm Loop 24V **ENTER**

HART SERVICE PVAO 4.0000 mA

Abort Fetch Send

Figure 15

- After completing Output Trim, press the **Done** softkey and proceed with the As Left verification test. Press the **As Left** softkey. Press **Done** and then press **Auto Test**. On completion, an error summary table is displayed. If errors are highlighted, the test has failed and further adjustment is required. Return to step 5 for adjustment of the 3144.

SOURCE	MEASURE	ERROR %
0.0 °C	3.988 mA	-0.08
150.0 °C	11.995 mA	-0.03
300.0 °C	20.006 mA	0.04

02/17/99 04:54:25 pm Loop 24V **ENTER**

Abort Prev. Page Next Page Done

Figure 16

Example 3

Calibration of HART instruments using universal commands

The 744 supports a majority of the installed workload of HART transmitters – see Table 1 – by supporting sensor trim, which employs device-specific commands that are unique to a particular instrument. So how can you calibrate instruments that are not supported by the 744?

The short answer is that the 744 supports a substantial set of the *universal* HART commands and the *common practice* HART commands. The 744 can communicate with virtually any HART instrument and, in most cases, can complete a calibration procedure (except for sensor trim for unsupported instruments).

This example applies to instruments used in analog mode (4–20 mA). If the instrument is operated in digital mode, i.e., its PV is the output variable that is used for control, a calibration of the Input Section is all that is needed. Adjustment will require a Sensor Trim, (see Figure 17) which means that for instruments not supported by the 744 you will need to use **both** a 744 (to perform the As Found and As Left tests and record the results) and a communicator (to perform sensor trim). For instruments used in analog mode, i.e., where the 4–20 mA analog output is used for control, the 744 can be used for calibration. After performing an As Found and

determining that adjustment is required, this example first performs an Output Trim to bring the instrument within tolerance. Failing that, the example performs an adjustment to the Lower and Upper Range Values (LRV and URV) to compensate for input section error.

Note: Appendix A explains that these adjustments do not constitute a proper HART calibration. While this is true, these adjustments are a practical calibration alternative for instruments operated in 4–20 mA analog mode if error corrections are not large

How to determine digital or analog?

The transmitter is in digital mode if its HART Poll Address is set between 1 to 15. An address of 0 (zero) sets it to 4–20 mA analog output mode. The 744 will automatically connect to a device at address 0; if a device is not found at 0 the 744 will begin polling

addresses 1 to 15. The 744 also displays a non-zero address with the basic HART information.

Basic connections

This example assumes that the transmitter is isolated from the process and is not electrically connected to a loop power supply. Make basic connections to the transmitter per the diagram in Figure 18. Polarity of the HART communication connection is not important. A separate 250 ohm resistor is not necessary because the 744 incorporates a resistor in series with the 24V loop supply through its mA jacks. This example assumes a type K thermocouple transmitter with an input range of 0–100 °C, 4–20 mA output, and a 0.25% test tolerance.

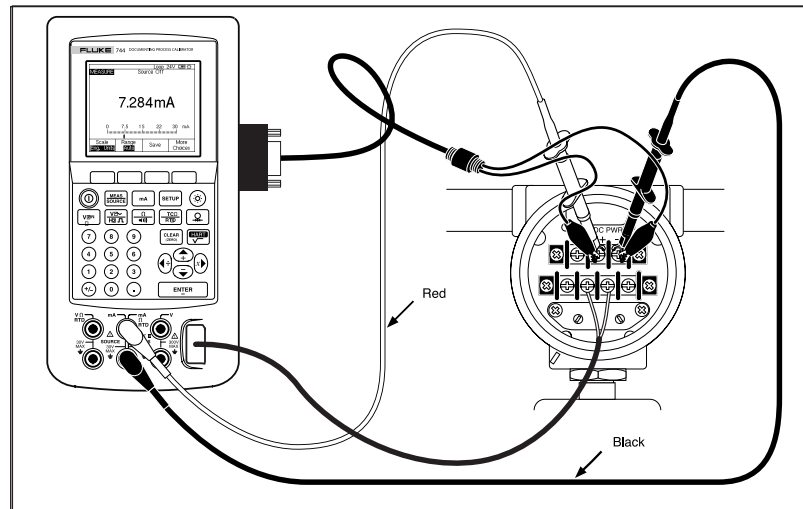

Figure 18

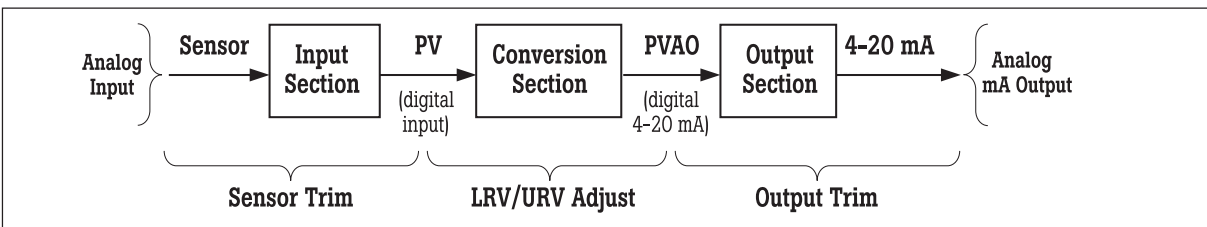

Figure 17

Procedure

1. Power on the Fluke 744 Calibrator. Press the **HART** key and the **Loop Power** softkey (if loop power is not already supplied). Press **ENTER** until any device warnings are cleared and the basic HART information is displayed (Figure 19).

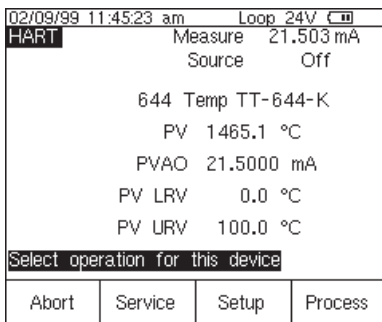

Figure 19

2. Press the **MEAS** key again and you are prompted to select the 744 configuration (Figure 20). Move the cursor to **MEAS mA, SOURCE T/C typ K**, and press **ENTER**. (If you were verifying the digital PV instead of the mA output, i.e., the transmitter has a non-zero HART poll address, you would select **MEAS PV, SOURCE T/C typ K** instead.)

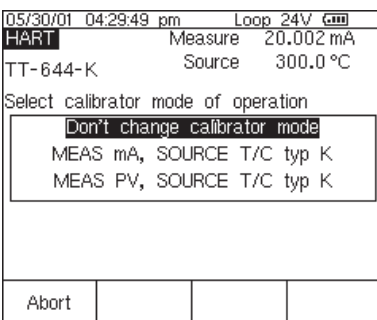

Figure 20

3. Press the **As Found** softkey and press **ENTER** to select **Instrument calibration**. Move the cursor to **Tolerance** and **ENTER** the appropriate test tolerance (0.25% in this example). Verify that the **0% Value** and **100% Value** are the proper, **nominal** operating values for the transmitter (0.0 °C and 100.0 °C in this example, Figure 21). If the Lower (0%) and Upper (100%) Range Values (LRV and URV) have been previously modified for calibration purposes, you will need to **ENTER** the nominal values. For example, if a previous calibration modified the URV to 100.2 °C, you need to manually **ENTER** the nominal value of 100.0 °C for the **100% Value**. Entering nominal zero and span values ensures that errors are calculated correctly.

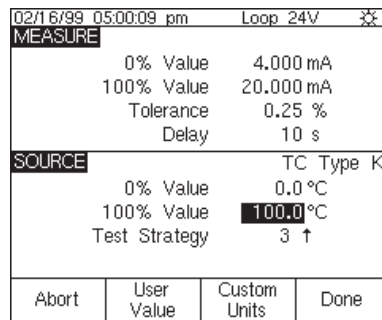

Figure 21

4. Press **Done** and then press **Auto Test**. Once the test is complete, an error summary table is displayed (Figure 22). Test errors exceeding the tolerance are highlighted. If the test passed, i.e., if no errors are highlighted, adjustment is not required.

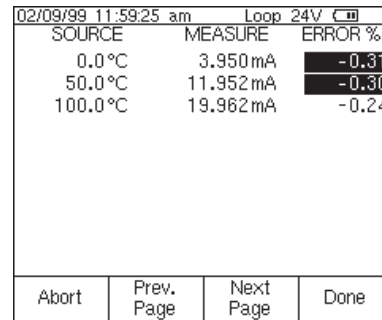

Figure 22

If errors are highlighted, adjustment is necessary by performing an Output Trim. Press **Done** to leave the results screen, edit the tag, serial number or ID fields as necessary, and press **Done** again.

5. Press the **Adjust** softkey, select **Output Trim** and press **ENTER**. The value of the primary variable (PVAO) is in the upper right corner of the display (Figure 23). This is normally a 4 mA signal. The real-time mA value as measured by the Fluke 744, is in the center of the display. Press the **Fetch** softkey to load the measured mA value. Press the **Send** softkey to send the value to the transmitter to trim the output section for the 4 mA value. Press **Continue** for the 20 mA adjustment and repeat this step.

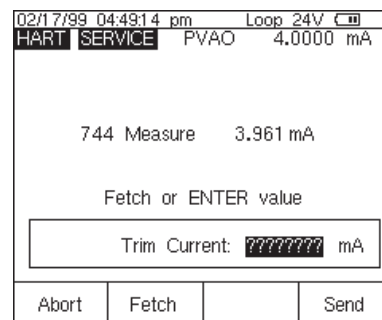

Figure 23

6. Now perform an As Left test. Press **As Left**, press **Done**, and then press **Auto Test**. On completion the error summary table is displayed. If errors are highlighted, the test has failed and further adjustment is required.

Note: If the failure error is large, sensor trim adjustment with a communicator may be necessary. Often, however, adjustment can be accomplished with a 744 by modifying the LRV (Lower Range Value) and URV (Upper Range Value) to compensate for Input Section error.

7. In the case of a pressure transmitter that has on-board Zero and Span adjustment buttons, calibration is easy. Simply apply a calibrated source at the LRV and URV values and press the respective Zero and Span buttons on the transmitter. Then verify the condition of the transmitter by completing an As Left test as in step 6. Many HART transmitters do not have physical adjustments and need either a communicator or a *Fluke 744* to adjust the LRV and URV values. For those cases, proceed to step 8.

8. The error summary table (displayed from step 6) provides the data necessary to make LRV and URV changes. Write down the ERROR % values for the failed 0% and 100% test points. (If the error summary table is no longer displayed, you can use the **Review Memory** softkey to recall the As Left data.) Return the 744 to the normal Measure/Source screen displaying the **As Left** softkey by pressing the **Done** softkey 3 times.

9. Calculate the new LRV or URV by multiplying the span by the error in percent and adding that to the old value. If our example has the following nominal Source values, errors, and old LRV and URV values:

	Source	Error%	Old LRV/URV
0% Value	0.0 °C	0.84%	0.4 °C
100% Value	100.0 °C	-2.41%	102.0 °C

Table 2

Calculate the new LRV and URV as follows:

$$LRV_{new} = LRV_{old} + (Span \times Error_{0\%})$$

$$LRV_{new} = 0.4 \text{ °C} + (100.0 \text{ °C} \times 0.84\%)$$

$$LRV_{new} = 0.4 \text{ °C} + (100.0 \text{ °C} \times 0.0084)$$

$$LRV_{new} = 0.4 \text{ °C} + 0.8 \text{ °C}$$

$$LRV_{new} = 1.2 \text{ °C}$$

$$URV_{new} = URV_{old} + (Span \times Error_{100\%})$$

$$URV_{new} = 102.0 \text{ °C} + (100.0 \text{ °C} \times -2.41\%)$$

$$URV_{new} = 102.0 \text{ °C} + (100.0 \text{ °C} \times -0.0241)$$

$$URV_{new} = 102.0 \text{ °C} - 2.4 \text{ °C}$$

$$URV_{new} = 99.6 \text{ °C}$$

10. Press **⇧** and then press the **Setup** softkey. Select **Basic** from the menu and press **ENTER** to display the basic setup parameters shown in Figure 24. To ENTER the new LRV, move the cursor to **Lower Range Value** and press **ENTER**. Type the new LRV and press **ENTER**. Also type in the new URV and press **ENTER**. Press the **Send** softkey.

02/16/99 12:26:09 pm		Loop 24V	⏏
HART SETUP	Measure	4.001 mA	
Press ENTER to change item			
	Tag	TT-644-K	
	PV Unit	°C	
	Lower Range Value	0.4 °C	
	Upper Range Value	102.0 °C	
	Damping	0.0000 s	
	Transfer Function	Linear	
Store Page	Recall Page	Reset Page	Done

Figure 24

11. Now press **Done** and then press **Abort** 3 times. Perform a new As Found test by pressing **As Found**. (Remember to make sure that the original, nominal zero and span values are shown as the **0% Value** and **100% Value**.) Press **Done** and then press **Auto Test**. On completion, the error summary table is displayed. If errors are highlighted, the test has failed – repeat the adjustment or trim sensor section with a communicator.

Appendix A

Calibrating HART Transmitters

By **Kenneth L. Holladay, P.E.**

Calibrating a conventional instrument

For a conventional 4–20 mA instrument, a multiple point test that stimulates the input and measures the output is sufficient to characterize the overall accuracy of the transmitter. The normal calibration adjustment involves setting only the zero value and the span value, since there is effectively only one adjustable operation between the input and output as illustrated below.

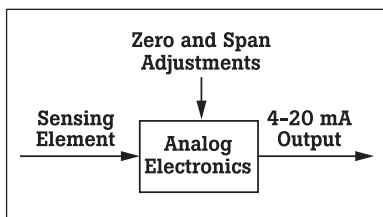

Figure A1
Conventional Transmitter Block Diagram

This procedure is often referred to as a Zero and Span Calibration. If the relationship between the input and output range of the instrument is not linear, then you must know the transfer function before you can calculate expected outputs for each input value. Without knowing the expected output values, you cannot calculate the performance errors.

Calibrating a HART instrument

For a HART instrument, a multiple point test between input and output does not provide an accurate representation of the transmitter's operation. Just like a conventional transmitter, the measurement process begins with a technology that converts a physical quantity into an electrical signal. However, the

similarity ends there. Instead of a purely mechanical or electrical path between the input and the resulting 4–20 mA output signal, a HART transmitter has a microprocessor that manipulates the input data. As shown in Figure A2, there are typically three calculation sections involved, and each of these sections may be individually tested and adjusted.

Just prior to the first box, the instrument's microprocessor measures some electrical property that is affected by the process variable of interest. The measured value may be millivolts, capacitance, reluctance, inductance, frequency, or some other property. However, before it can be used by the microprocessor, it must be transformed to a digital count by an analog to digital (A/D) converter.

In the first box, the microprocessor must rely upon some form of equation or table to relate the raw count value of the electrical measurement to the actual property (PV) of interest such as temperature, pressure, or flow. The principle form of this table is usually established by the manufacturer, but most HART instruments include commands to perform field adjustments. This is often referred to as a sensor trim. The output of the first box is a digital representation of the process variable. When you read the process variable using a communicator, this is the value that you see. The second box is strictly a

mathematical conversion from the process variable to the equivalent milliamp representation. The range values of the instrument (related to the zero and span values) are used in conjunction with the transfer function to calculate this value. Although a linear transfer function is the most common, pressure transmitters often have a square root option. Other special instruments may implement common mathematical transformations or user defined break point tables. The output of the second block is a digital representation of the desired instrument output. When you read the loop current using a communicator, this is the value that you see. Many HART instruments support a command which puts the instrument into a fixed output test mode. This overrides the normal output of the second block and substitutes a specified output value. The third box is the output section where the calculated output value is converted to a count value that can be loaded into a digital to analog converter. This produces the actual analog electrical signal. Once again the microprocessor must rely on some internal calibration factors to get the output correct. Adjusting these factors is often referred to as a current loop trim or 4–20 mA trim.

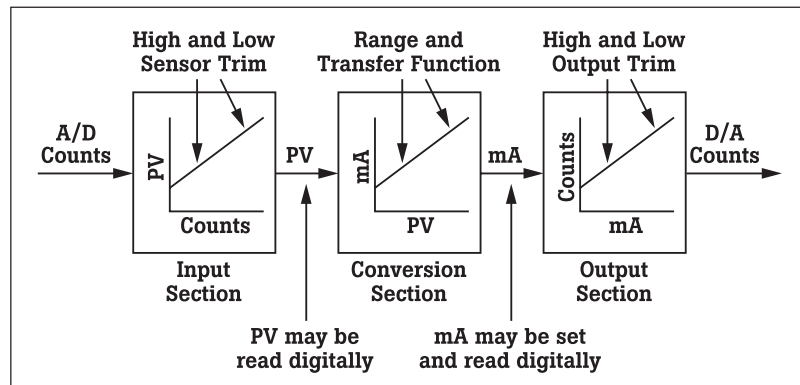

Figure A2
HART Transmitter Block Diagram

HART calibration requirements

Based on this analysis, you can see why a proper calibration procedure for a HART instrument is significantly different than for a conventional instrument. The specific calibration requirements depend upon the application.

If the application uses the digital representation of the process variable for monitoring or control, then the sensor input section must be explicitly tested and adjusted. Note that this reading is completely independent of the milliamp output, and has nothing to do with the zero or span settings. The PV as read via HART communication continues to be accurate even when it is outside the assigned output range. For example, a range 2 Rosemount 3051c has sensor limits of -250 to +250 inches of water. If you set the range to 0 - 100 inches of water, and then apply a pressure of 150 inches of water, the analog output will saturate at just above 20 milliamps. However, a communicator can still read the correct pressure.

If the current loop output is not used (that is the transmitter is used as a digital only device), then the input section calibration is all that is required. If the application uses the milliamp output, then the output section must be explicitly tested and calibrated. Note that this calibration is independent of the input section, and again, has nothing to do with the zero and span settings.

Calibrating the input section

The same basic multiple point test and adjust technique is employed, but with a new definition for output. To run a test, use a calibrator to measure the applied input, but read the associated output (PV) with a communicator. Error calculations are simpler since there is

always a linear relationship between the input and output, and both are recorded in the same engineering units. In general, the desired accuracy for this test will be the manufacturer's accuracy specification. If the test does not pass, then follow the manufacturer's recommended procedure for trimming the input section. This may be called a sensor trim and typically involves one or two trim points. Pressure transmitters also often have a zero trim, where the input calculation is adjusted to read exactly zero (not low range). Do not confuse a trim with any form of re-ranging or any procedure that involves using zero and span buttons.

Calibrating the output section

Again, the same basic multiple point test and adjust technique is employed, but with a new definition for input. To run a test, use a communicator to put the transmitter into a fixed current output mode. The input value for the test is the mA value that you instruct the transmitter to produce. The output value is obtained using a calibrator to measure the resulting current. This test also implies a linear relationship between the input and output, and both are recorded in the same engineering units (milliamps). The desired accuracy for this test should also reflect the manufacturer's accuracy specification.

If the test does not pass, then follow the manufacturer's recommended procedure for trimming the output section. This may be called a 4-20 mA trim, a current loop trim, or a D/A trim. The trim procedure should require two trim points close to or just outside of 4 and 20 mA. Do not confuse this with any form of re-ranging or any procedure that involves using zero and span buttons.

Testing overall performance

After calibrating both the Input and Output sections, a HART transmitter should operate correctly. The middle block in Figure A2 only involves computations. That is why you can change the range, units, and transfer function without necessarily affecting the calibration. Notice also that even if the instrument has an unusual transfer function, it only operates in the conversion of the input value to a milliamp output value, and therefore is not involved in the testing or calibration of either the input or output sections.

If there is a desire to validate the overall performance of a HART transmitter, run a Zero and Span test just like a conventional instrument. As you will see in a moment, however, passing this test does not necessarily indicate that the transmitter is operating correctly.

Effect of damping on test performance

Many HART instruments support a parameter called damping. If this is not set to zero, it can have an adverse effect on tests and adjustments. Damping induces a delay between a change in the instrument input and the detection of that change in the digital value for the instrument input reading and the corresponding instrument output value. This damping induced delay may exceed the settling time used in the test or calibration. The settling time is the amount of time the test or calibration waits between setting the input and reading the resulting output. It is advisable to adjust the instrument's damping value to zero prior to performing tests or adjustments. After calibration, be sure to return the damping constant to its required value.

Operations that are NOT proper calibrations

Digital range change

There is a common misconception that changing the range of a HART instrument by using a communicator somehow calibrates the instrument. Remember that a true calibration requires a reference standard, usually in the form of one or more pieces of calibration equipment to provide an input and measure the resulting output. Therefore, since a range change does not reference any external calibration standards, it is really a configuration change, not a calibration. Notice that in the HART transmitter block diagram (Figure 2), changing the range only affects the second block. It has no effect on the digital process variable as read by a communicator.

Zero and span adjustment

Using only the zero and span adjustments to calibrate a HART transmitter (the standard practice associated with conventional transmitters) often corrupts the internal digital readings. You may not have noticed this if you never use a communicator to read the range or digital process data. As shown in Figure 2, there is more than one output to consider. The digital PV and milliamp values read by a communicator are also outputs, just like the analog current loop. Consider what happens when using the external zero and span buttons to adjust a HART instrument. Suppose that an instrument technician installs and tests a differential pressure transmitter that was set at the factory for a range of 0 to 100 inches of water. Testing the transmitter reveals that it now has a 1 inch of water zero shift. Thus with

both ports vented (zero), its output is 4.16 mA instead of 4.00 mA, and when applying 100 inches of water, the output is 20.16 mA instead of 20.00 mA. To fix this he vents both ports and presses the zero button on the transmitter. The output goes to 4.00 mA, so it appears that the adjustment was successful.

However, if he now checks the transmitter with a communicator, he will find that the range is 1 to 101 inches of water, and the PV is 1 inch of water instead of 0. The zero and span buttons changed the range (the second block). This is the only action that the instrument can take under these conditions since it does not know the actual value of the reference input. Only by using a digital command which conveys the reference value can the instrument make the appropriate internal adjustments.

The proper way to correct a zero shift condition is to use a zero trim. This adjusts the instrument input block so that the digital PV agrees with the calibration standard. If you intend to use the digital process values for trending, statistical calculations, or maintenance tracking, then you should disable the external zero and span buttons and avoid using them entirely.

Loop current adjustment

Another observed practice among instrument technicians is to use a hand-held communicator to adjust the current loop so that an accurate input to the instrument agrees with some display device on the loop. If you are using a Rosemount model 268 communicator, this is a "current loop trim using other scale." Refer again to the zero drift example just before pressing the zero button.

Suppose there is also a digital indicator in the loop that displays 0.0 at 4 mA, and 100.0 at 20 mA. During testing, it read 1.0 with both ports vented, and it read 101.0 with 100 inches of water applied. Using the communicator, the technician performs a current loop trim so that the display reads correctly at 0 and 100, essentially correcting the output to be 4 and 20 mA respectively. While this also appears to be successful, there is a fundamental problem with this procedure. To begin with, the communicator will show that the PV still reads 1 and 101 inches of water at the test points, and the digital reading of the mA output still reads 4.16 and 20.16 mA, even though the actual output is 4 and 20 mA. The calibration problem in the input section has been hidden by introducing a compensating error in the output section, so that neither of the digital readings agrees with the calibration standards.

As published in *Intech*, May 1996 and also in *HART Book 8*, July 1998. Reprinted with the permission of the author.

**Fluke tools for the Process Industry:
Calibrate and troubleshoot
all your process
instrumentation.**

The Fluke range of process tools give you all the choice you need to maintain and calibrate virtually all types of sensors and transmitters. Whether you want all the required functionality in just one tool, or a dedicated tool for temperature or pressure only, the choice is yours.

Check our complete line of Process Meters, Documenting, Multifunction, Temperature, Pressure and Loop Calibrators and see for yourself how you can maximize your maintenance efficiency.



Ordering Information

FLUKE-744 Documenting Process Calibrator-HART

Includes: TL24 Industrial Test Leads (two sets), AC20 Test Clips (2 sets), TP20 Test Probes (1 set), BP7235 NiMH Battery Pack, BC7217 Battery Charger, serial port cable, HART communications cable, DPC/TRACK Sample with free PC communication utility software, Instruction Manual, HART User's Manual, NIST-traceable calibration certificate and data, three-year warranty.

Optional Accessories

- | | |
|----------------------|---|
| Fluke-700 Pxx | Pressure Modules
Included with each Fluke Pressure Module: BSP-ISO to NPT Adapter(s) (except with P29 - P31), Instruction Sheet, NIST traceable calibration report and data, one-year warranty. |
| Fluke-700BCW | Bar Code Wand |
| Fluke-700PTP | Pneumatic Test Pump, 360 psi/25 bar |
| Fluke-700TC1 | TC Mini-Plug Kit, 9 types |
| Fluke-700TC2 | TC Mini-Plug Kit, JKTERS |
| BE9005 | Battery Eliminator |
| BC7217 | Battery Charger |
| BP7217 | NiCd Battery Pack |
| BP7235 | NiMH Battery Pack |
| C700 | Hard Carrying Case |
| C781 | Soft Carrying Case |
| C789 | Soft Carrying Case |
| Fluke-744V20 | HART Upgrade Revision 2.3 |

Documentation of results

The scheduling of calibrations, creation of procedures and documentation of your calibration results are facilitated by a number of instrumentation management software packages:

Honeywell DocuMint™



PRM (Plant Resource Manager) from Yokogawa Electric Corporation.

On Time Support™

Fluke DPC/TRACK™

Fluke. Keeping your world up and running.

Fluke Corporation
PO Box 9090, Everett, WA USA 98206
Fluke Europe B.V.
PO Box 1186, 5602 BD
Eindhoven, The Netherlands

For more information call:
U.S.A. (800) 443-5853 or Fax (425) 446-5116
Europe/M-East/Africa +1 (31 40) 2 675 200 or
Fax +1 (31 40) 2 675 222
Canada 1-800-36-FLUKE or Fax (905) 890-6866
Other countries +1 (425) 446-5500 or
Fax +1 (425) 446-5116
Web access: <http://www.fluke.com>

